

ER-4915

ELECTRONIC CASH REGISTER

DEALER POCKET PROGRAMMING GUIDE

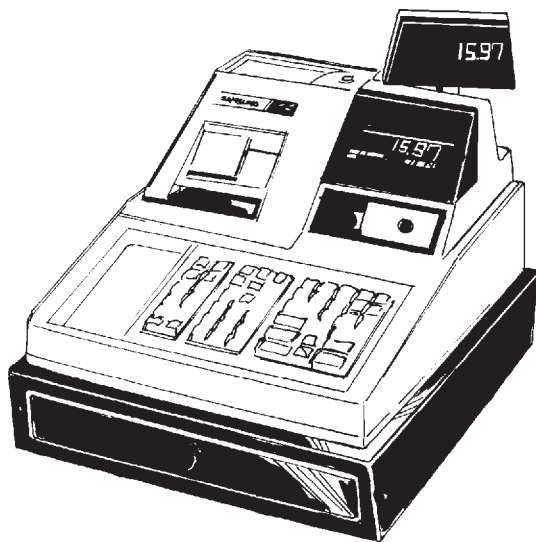

Table of Contents

Keylock	3
Keyboard	4
S-Mode Set-Up	5
Tax Programming	6
Department Programming	10
PLU Programming	13
% Key Programming	17
CASH TEND Key Programming	19
CHECK Key Programming	20
CHARGE Key Programming	21
Food Stamp Amount Tendered Programming	22
Currency Conversion Programming	23
Clerk Secret Code Programming	24
Clerk Drawer Assignment Programming	24
Clerk Descriptors Programming	25
System Options Programming	26
Receipt Message Programming	30
Drawer Limit Programming	31
Register Number Programming	31
Date Programming	31
Time Programming	31
Program Scans	32
System Reports	34
System Balancing	35

Keylock

The Keylock has 7 positions, with 5 keys. Each ECR is shipped with two full sets of keys.

Keys Include:

1. 'REG' - travel from 'OFF' to 'REG'.
2. 'VOID' - travel from 'X' to 'VOID'.
3. 'Z' - travel from 'Z' to 'VOID'.
4. 'P' - travel from 'P' to 'VOID'.
5. 'C' - travel to all key positions.*

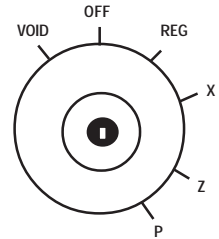

NOTE: Keys are removable from the 'OFF' and 'REG' positions only.

Keyboard

The 60 position keyboard is shown below with standard five departments.

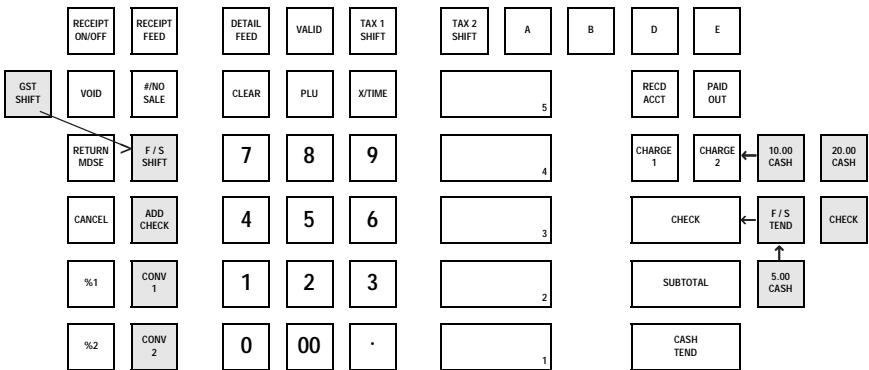

NOTE: The above keyboard indicates the positions for optional function keys. These keys have been shaded in the illustration and may or may not be installed on your machine.

Keyboard, continued

Optional Ten Department Configuration

RECEIPT ON/OFF	RECEIPT FEED	DETAIL FEED	VALID	TAX 1 SHIFT	TAX 2 SHIFT	A	B	D	E
VOID	#/NO SALE	CLEAR	PLU	X/TIME	5	10	RECD ACCT	PAID OUT	
RETURN MDSE		7	8	9	4	9	CHARGE 1	CHARGE 2	
CANCEL		4	5	6	3	8	CHECK		
%1		1	2	3	2	7	SUBTOTAL		
%2		0	00	.	1	6	CASH TEND		

Optional Fifteen/Thirty Department Configuration

RECEIPT ON/OFF	RECEIPT FEED	DETAIL FEED	VALID	TAX 1 SHIFT	TAX 2 SHIFT	A	B	D	E
VOID	#/NO SALE	CLEAR	PLU	X/TIME	5/20	10/25	15/30	RECD ACCT	PAID OUT
RETURN MDSE		7	8	9	4/19	9/24	14/29	CHARGE 1	CHARGE 2
CANCEL		4	5	6	3/18	8/23	13/28	CHECK	
%1		1	2	3	2/17	7/22	12/27	SUBTOTAL	DEPT SHIFT
%2		0	00	.	1/16	6/21	11/26	CASH TEND	SUB TOTAL

NOTE: The above keyboard shows the 15 department configuration with the optional DEPT SHIFT key for departments 16 through 30

S-Mode Set-Up

<u>Self Tests</u>		<u>Key Sequence</u>
Function	Keylock Position	
Initialize	P-Mode	Power up machine while holding down the "SUBTOTAL" key.
Memory All Clear	"C" key to the S-Mode position	Power up machine while holding down the "00" key.
Reset All Totals & Counters	"C" key to the S-Mode position	Power up machine while holding down the "CHECK" key.
Reset Grand Total Only	"C" key to the S-Mode position	Power up machine while holding down the "CASH TEND" key.
Printer & Display Test	"C" key to the S-Mode position	Enter 1 and press the "CASH TEND" key.
Keyboard Test	"C" key to the S-Mode position	Enter 2 and press the "CASH TEND" key. Exit test mode by pressing the "CLEAR" key twice.
Keylock Test	"C" key to the S-Mode position	Enter 3 and press the "CASH TEND" key. Rotate the "C" key to all keylock positions.
EPROM Check Sum	"C" key to the S-Mode position	Enter 4 and press the "CASH TEND" key.
S-Mode Programming		
Setting the Number of Departments	"C" key to the S-Mode position	Enter the number of Departments (5, 10, or 15), press the "X/TIME" key, and "CASH TEND" key.

NOTE: The ER-4915 may be initialized (Initial Cleared) at any time. The Initial Clear procedure may be used to clear keyboard lock-ups and constant error conditions. An Initial Clear will not affect register programming or clear previously stored totals from memory. However, an Initial Clear *will* cause balancing discrepancies if performed in the middle of a transaction.

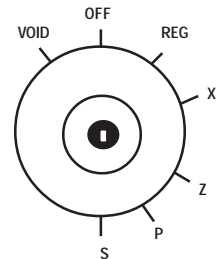

The Service mode (S-Mode) position is at "6 o'clock" on the keylock. It is not labeled, and can be accessed only by the "C" key. See the above illustration.

Tax Programming

Straight Percentage Tax Programming

When tax requirements may be met using a straight percentage, use the following method to program a tax as a straight percentage.

Straight percentage tax programming requires a seven-digit entry (labeled N1 - N7 below). This assigns the rate as well as a two digit option code defining the tax as add-on, inclusive (VAT), and/or Canadian GST type tax. The rate is designated as 1, 2, or 3 using the appropriate shift key.

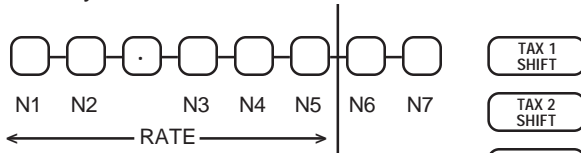

*Tax Rate 3 programming does not apply to registers programmed for Food Stamp operations.

Percentage and status programming is determined as follows:

Enter the rate (digits N1 through N5), using the decimal key, leading zeros are not required (6.000 = 6%, 10.500 10.5%, etc.). This is followed by the status (two digits), then press TAX 1 SHIFT for tax 1, TAX 2 SHIFT for tax 2, or TAX 3 SHIFT for tax 3. Percentage tax programming for that rate is complete.

To arrive at a status value for N6 & N7 use the chart below. N7 must be "0" for rates 1 & 2.

Carry the desired value for addresses with single options directly to the "SUM" column. For addresses with multiple choices, enter values of individual options in "=" column, add, and enter the combined value in the "SUM" column.

ADDRESS	TAX PROGRAMMING OPTIONS	VALUE	=	SUM
N6	Tax is Straight % / Add On	= 0		
	Tax is Tax Table / Add On	= 1		
	Tax is Straight % / VAT	= 2		
N7	GST (Tax 3) is taxable by Rate 1	YES = 1	(A)	
		NO = 0		
	GST (Tax 3) is taxable by Rate 2	YES = 2	(B)	(A+B)
		NO = 0		

Tax Table Programming

- Maximum 47 tax breaks.
- Tax breaks determine at what dollar amount an additional .01 will be added to the tax total of the sale.
- Determine break points by subtracting the high side of a dollar range from the high side of the next dollar range.
- The pattern of break points is the repeat breaks pattern.
- The beginning break points, that do not fit into the repeat breaks pattern are the non-repeat breaks.
- The following example uses a 6% Illinois tax.

Sample Tax Table

TAX CHARGED	SALE DOLLAR RANGE		BREAK POINTS
	LOW SIDE	HIGH SIDE	
- \$.00	\$.00	- \$.10	
.01	.11	- .21	11
.02	.22	- .38	17
.03	.39	- .56	18
.04	.57	- .73	17
.05	.74	- .91	18
.06	.92	- 1.08	17
.07	1.09	- 1.24	16
.08	1.25	- 1.41	17
.09	1.42	- 1.58	17
.10	1.59	- 1.74	16
.11	1.75	- 1.91	17
.12	1.92	- 2.08	17
.13	2.09	- 2.24	16
.14	2.25	- 2.41	17

If Tax rate 3 is designated as GST, table programming is not allowed for that rate.

NOTE: 10 is maximum non-taxable amount in this example. .01 is the first tax amount charged.

Tax Programming, continued

Programming Procedure

- Enter the option code for N6 & N7 from the table on page 6. It is not necessary to enter leading zeros for N1 - N5.
- Enter the maximum non-taxable amount. Depress the TAX SHIFT key associated with the rate you wish to program.
- Enter the first tax amount charged (1). Depress the TAX SHIFT key associated with the rate you wish to program.
- Enter the high side of the dollar range for the first non-repeat break which charges tax (21). Depress the DECIMAL key.
- Repeat Step 3 for each non-repeat break (38), (56), (73)
- Enter the final non-repeat break (91), and depress the X/TIME key.
- Enter the high side of the dollar range for the first repeat break in the repeat breaks pattern (108). Depress the DECIMAL key.
- Enter the high side of the dollar range for the next repeat break in the repeat break pattern and for each following repeat break in the repeat break pattern (124), (141). Depress the DECIMAL key.
- Depress the CASH TEND key to finalize Tax Table Programming.

Programming Example

Tax 1 is a 5% add-on straight percentage

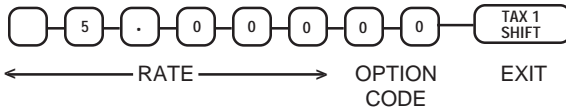

This completes programming for Rate 1

Tax 2 is a 6% add-on tax table

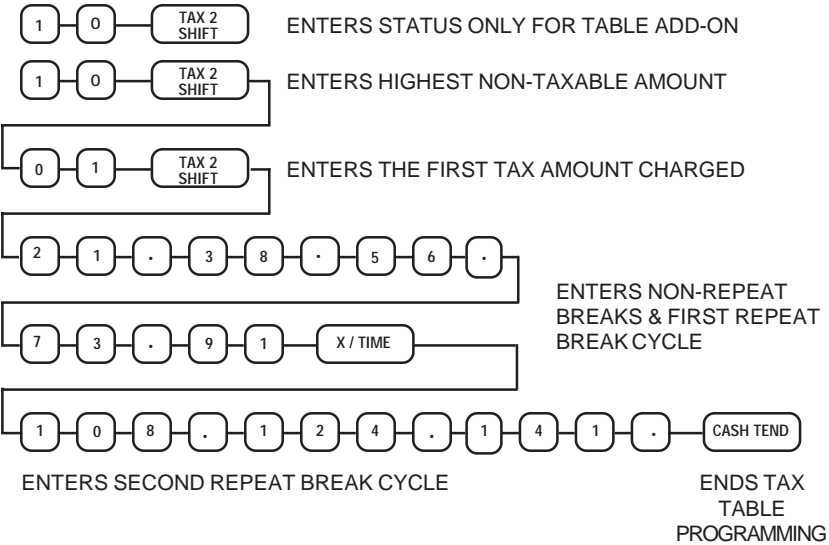

Department Programming

Programming Options

Carry the desired value for addresses with single options directly to the "SUM" column. For addresses with multiple choices, enter values of individual options in "=" column, add, and enter the combined value in the "SUM" column.

ADDRESS	DEPARTMENT OPTIONS	VALUE	=	SUM
N1	Hash Department feature activated	YES = 1	(A)	
		NO = 0		
	Gallonage Department feature activated	YES = 2	(B)	
		NO = 0		
	Enforce Non-add Entry	YES = 4	(C)	(A+B+C)
		NO = 0		
N2	Department is NEGATIVE	YES = 1	(A)	
		NO = 0		
	SINGLE ITEM	YES = 2	(B)	
		NO = 0		
	Validation Compulsory	YES = 4	(C)	(A+B+C)
		NO = 0		
N3	Department is	OPEN DEPT. = 0		
		PRESET DEPT. = 1		
		DISABLED = 2		
N4	Department is TAXABLE AT RATE 1	YES = 1	(A)	
		NO = 0		
	TAXABLE AT RATE 2	YES = 2	(B)	
		NO = 0		
	TAXABLE AT RATE 3 OR FOOD STAMP ELIGIBLE * System programming option 31 specifies the use of either Tax rate 3 (Canadian GST - Goods and Services Tax) or Food Stamp function for both departments and PLUs.	YES = 4	(C)	(A+B+C)
		NO = 0		

NOTE: Negative hash departments and negative gallonage departments are *not* allowed. Also, compulsory validation is *not* allowed on single item departments.

Department Programming Key Sequence

Enter the three digit address for department status programming (100) and depress the SUBTOTAL key. Then, enter the desired four digit status and depress each department key to be assigned that status. Depress the CASH TEND key to complete status programming.

If the status is to be assigned to one department only, simply depress that department key, followed by the CASH TEND key to complete status programming.

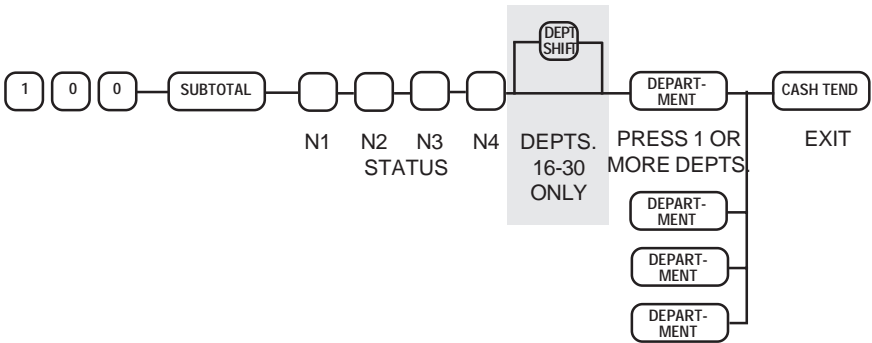

NOTE: DEPT SHIFT functions as “Stay Down” in P-mode only.

Programming Price/Price Lock-Out

To establish a preset price, or High Amount Lock-Out, enter the three digit address for department price/HALO programming (110), and depress the SUBTOTAL key. Then enter the amount and depress the appropriate department key. A zero amount entry for open departments will set the HALO at the maximum seven digits (99999.99) for departments. Zero preset departments are allowed.

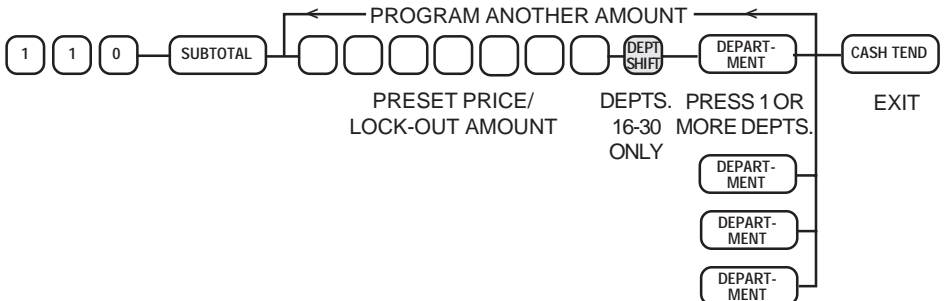

Department Programming, continued

Department Descriptor Programming

Each department is allowed an alpha-descriptor of up to twelve characters. Programming twelve letters requires the entry of 24 digits (a two-digit code for each letter). Codes for each of the available characters are shown in the chart below.

Alpha Codes

DESCRIPTOR CODES										
CHAR	SPAC	!	"	#	\$	%	&	'	()
CODE	32	33	34	35	36	37	38	39	40	41
CHAR	*	+	,	-	.	/	0	1	2	3
CODE	42	43	44	45	46	47	48	49	50	51
CHAR	4	5	6	7	8	9	:	;	<	=
CODE	52	53	54	55	56	57	58	59	60	61
CHAR	>	?	@	A	B	C	D	E	F	G
CODE	62	63	64	65	66	67	68	69	70	71
CHAR	H	I	J	K	L	M	N	O	P	Q
CODE	72	73	74	75	76	77	78	79	80	81
CHAR	R	S	T	U	V	W	X	Y	Z	[
CODE	82	83	84	85	86	87	88	89	90	91
CHAR	\]	^	-	`	DOUBLE WIDE		Double wide characters must be preceded w/ "99", and count as two characters		
CODE	92	93	94	95	96	99				

Department Descriptor Programming Key Sequence

Begin programming department alpha descriptors by entering the four-digit programming address (1200) followed by the SUBTOTAL key. Now enter up to 24 digits (12 characters x 2 digits) and press the department key being programmed. Press the CASH TEND key to exit department descriptor programming, or enter descriptor codes for the next department to be programmed.

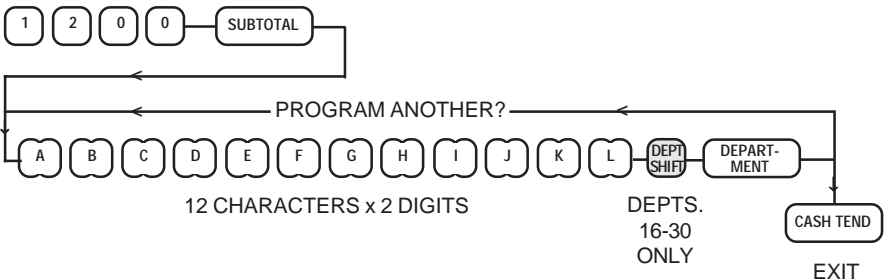

PLU Programming

Programming Options

Carry the desired value for addresses with single options directly to the “SUM” column. For addresses with multiple choices, enter values of individual options in “=” column, add, and enter the combined value in the “SUM” column.

ADDRESS	PLU STATUS	VALUE	=	SUM
N1	Hash PLU feature activated	YES = 1	(A)	
		NO = 0		
	Gallonage PLU feature activated	YES = 2	(B)	
		NO = 0		
	Enforce Compulsory Non-add # Entry	YES = 4	(C)	(A+B+C)
		NO = 0		
N2	PLU is NEGATIVE	YES = 1	(A)	
		NO = 0		
	SINGLE ITEM	YES = 2	(B)	
		NO = 0		
	Validation Compulsory	YES = 4	(C)	(A+B+C)
		NO = 0		
N3	PLU is: PLUs may not be programmed to be both open and preset.	OPEN PLU = 0		
		PRESET PLU = 1		
		DISABLED = 2		
N4	PLU is TAXABLE AT RATE 1	YES = 1	(A)	
		NO = 0		
	TAXABLE AT RATE 2	YES = 2	(B)	
		NO = 0		
	TAXABLE AT RATE 3 OR FOOD STAMP ELIGIBLE * System programming option 31 specifies the use of either Tax rate 3 (Canadian GST) or Food Stamp function.	YES = 4	(C)	(A+B+C)
		NO = 0		

NOTE: Negative hash PLUs and negative gallonage PLUs are *not* allowed. Also, compulsory validation is *not* allowed on single item PLUs.

PLU Programming, continued

PLU Programming Key Sequence

Enter the three digit address for PLU programming (200) and depress the SUBTOTAL key. Index the number of the beginning PLU of the range to be programmed, depress the PLU key. Index the number of the final PLU in the range being programmed, and press the PLU key.

Enter the status (four digits), and press the department key, or enter the price (up to six digits), and press the X/TIME key.

Finalize each step of programming by depressing the CASH TEND key.

Each PLU number which falls within the specified range will take on the status or price designated in this programming step.

In order to program a single PLU, enter one number only, (skip the "TO" PLU entry) followed by the PLU key, as the first step in the procedure.

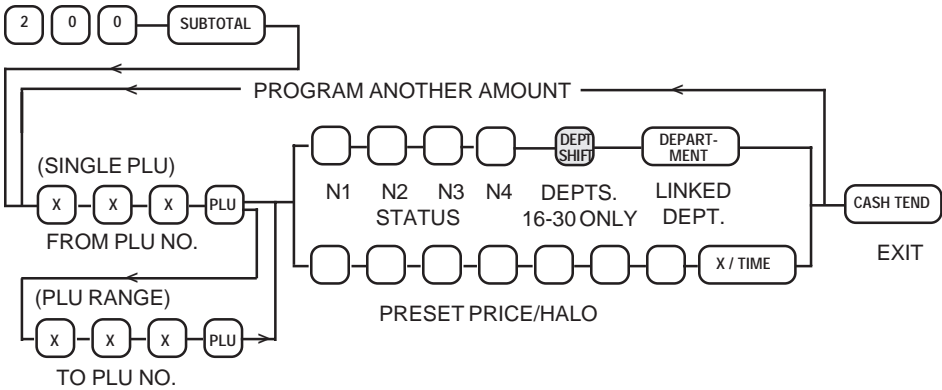

This programming chart allows for programming one, or a range of PLUs for status and linked department, and/or price/HALO amounts. This chart also allows programming of both status and price/HALO. It is possible to assign a new status to a PLU with out entering the price, just as it is possible to enter the price without having to re-enter the status.

For status only, enter 200 SUBTOTAL, the PLU number, press the PLU key, and follow with the status and linked department. Press the CASH TEND key to exit or begin again by entering another PLU number.

For price only, enter 200 SUBTOTAL, the PLU number and press the PLU key as above. Then enter the new price or HALO followed by the X/TIME key. Press the CASH TEND key to exit or begin again by entering another PLU number.

PLU Descriptor Programming

Each PLU is allowed an alpha-descriptor of up to twelve characters. Programming twelve letters requires the entry of 24 digits (a two-digit code for each letter). Codes for each of the available characters are shown in the chart below.

Alpha Codes

DESCRIPTOR CODES										
CHAR	SPAC	!	"	#	\$	%	&	'	()
CODE	32	33	34	35	36	37	38	39	40	41
CHAR	*	+	,	-	.	/	0	1	2	3
CODE	42	43	44	45	46	47	48	49	50	51
CHAR	4	5	6	7	8	9	:	;	<	=
CODE	52	53	54	55	56	57	58	59	60	61
CHAR	>	?	@	A	B	C	D	E	F	G
CODE	62	63	64	65	66	67	68	69	70	71
CHAR	H	I	J	K	L	M	N	O	P	Q
CODE	72	73	74	75	76	77	78	79	80	81
CHAR	R	S	T	U	V	W	X	Y	Z	[
CODE	82	83	84	85	86	87	88	89	90	91
CHAR	\]	^	-	`	DOUBLE WIDE		Double wide characters must be preceded w/ "99", and count as two characters		
CODE	92	93	94	95	96	99				

PLU Descriptor Programming Key Sequence

Begin programming PLU alpha descriptors by entering the four-digit programming address (1300) followed by the SUBTOTAL key. Now enter the 3 digit PLU number and press the PLU key. Enter up to 24 digits (12 characters x 2 digits) and press the PAID OUT key. Press the CASH TEND key to exit PLU descriptor programming, or enter the PLU number and descriptor codes for the next PLU to be programmed.

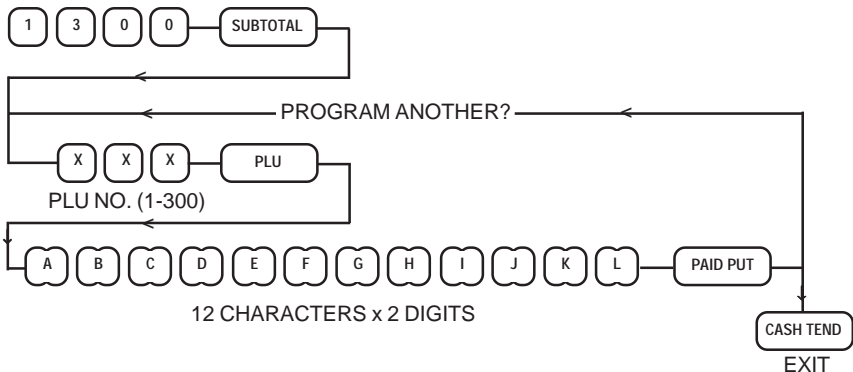

PLU Programming, continued

Programming Linked PLUs

The following procedure is used to link two or more PLUs. Once linked, the second PLU will follow automatically when the first is registered.

In P-Mode:

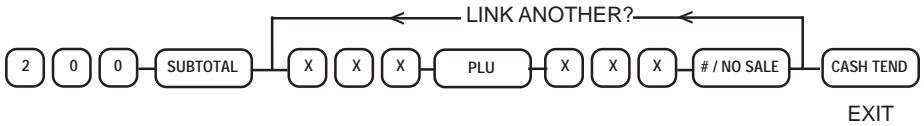

Removing or Deleting a PLU

In order to “de-activate” a PLU, or remove its status and department link thereby removing it from reports:



In Program mode, enter 200 SUBTOTAL, the PLU number, press the PLU key, followed by the VOID key. Press the CASH TEND key to finalize programming.

% Key 1 - 2 Programming

The % key may be programmed either positive or negative, as an open or preset amount or percentage. The % key may also be programmed to tax either the original or net amount.

Programming Options

Carry the desired value for addresses with single options directly to the "SUM" column. For addresses with multiple choices, enter values of individual options in "=" column, add, and enter the combined value in the "SUM" column.

ADDRESS	% OPTIONS	VALUE	=	SUM
N1	Tax status: Taxable by tax 1	YES = 1	(A)	
		NO = 0		
	Taxable by tax 2	YES = 2	(B)	
		NO = 0		
	Taxable by tax 3	YES = 4	(C)	(A+B+C)
		NO = 0		
N2	Discount/Surcharge is	POSITIVE = 1	(A)	
		NEGATIVE = 0		
	Discount/Surcharge is	OPEN = 2	(B)	(A+B)
		PRESET = 0		
N3	Discount/Surcharge is	SALE = 1	(A)	
		ITEM = 0		
	Discount/Surcharge is	AMOUNT = 2	(B)	
		PERCENTAGE = 0		
	Discount/Surcharge is	INACTIVE = 4	(C)	(A+B+C)
		ACTIVE = 0		

NOTE: If % key status = 002 or 022, it will function as Store Coupon Key. Also, if value for N2 is 1 or 3, then values for N3 of 2 and 3 are not allowed.

% Key 1 - 2 Programming, continued

First Programming Step

Determine the desired status for % key options (N1, N2, and N3 on page 17). Enter the address for the appropriate % key, 301 for %1, 302 for %2, and press SUBTOTAL. Enter the desired status and press the CASH TEND key.

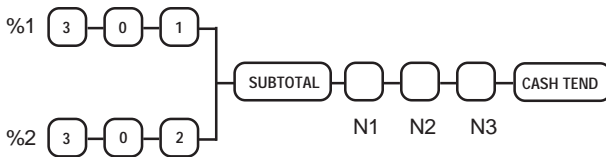

Second Programming Step

Based on status programming, enter one of the following:

A. Percentage preset or HALO (up to 4 digits w/decimal fixed at two places)

— or —

B. Amount preset or HALO (up to 4 digits w/decimal fixed at two places)

Enter the address for the appropriate % key, 311 for %1 key, 312 for %2 key and press SUBTOTAL. Enter the four digit percentage or HALO and press CASH TEND key.

-
- NOTE: ■ If % keys are programmed non-taxable, tax is calculated on the gross taxable amount before the % key is subtracted from that amount.
- If % key is programmed taxable by Tax 1, Tax 1 is calculated on the net amount taxable by Tax 1% (the amount taxable by tax 1 minus the % key) key entry.
 - If programmed taxable by Tax 2, Tax 2 is calculated on the net amount taxable by tax 2.
 - If programmed taxable by Tax 1 and Tax 2, both taxes are calculated on the net amount taxable by both taxes.
-

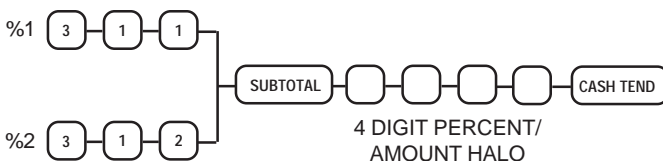

CASH TEND Key Programming

Programming Options

Carry the desired value for addresses with single options directly to the “SUM” column. For addresses with multiple choices, enter values of individual options in “=” column, add, and enter the combined value in the “SUM” column.

ADDRESS	CASH OPTIONS	VALUE	=	SUM
N1	Sale is Exempt from Tax 1	YES = 1	(A)	
		NO = 0		
	Sale is Exempt from Tax 2	YES = 2	(B)	
		NO = 0		
	Sale is Exempt from Tax 3	YES = 4	(C)	(A+B+C)
		NO = 0		
N2	Amount tender is compulsory on cash tender.	YES = 1	(A)	
		NO = 0		
	Under-tendering is disallowed.	YES = 2	(B)	
		NO = 0		
	Validation is compulsory.	YES = 4	(C)	(A+B+C)
		NO = 0		

CASH TEND Key Programming Key Sequence

Enter the address for CASH TEND key programming (400), and press SUBTOTAL. Enter the desired status for options N1 and N2 from the table above, and press the CASH TEND key.

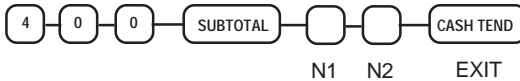

CHECK Key Programming

Carry the desired value for addresses with single options directly to the "SUM" column. For addresses with multiple choices, enter values of individual options in "=" column, add, and enter the combined value in the "SUM" column.

Programming Options

ADDRESS	CHECK OPTIONS	VALUE	=	SUM
N1	Sale is Exempt from Tax 1	YES = 1	(A)	
		NO = 0		
	Sale is Exempt from Tax 2	YES = 2	(B)	
		NO = 0		
	Sale is Exempt from Tax 3	YES = 4	(C)	(A+B+C)
		NO = 0		
N2	Amount tender is compulsory on check tender.	YES = 1	(A)	
		NO = 0		
	Inhibit under-tendering.	YES = 2	(B)	(A+B)
		NO = 0		

CHECK Key Programming Key Sequence

First Programming Step

Enter the program address for the CHECK key (500) and press SUBTOTAL. Enter the desired status, from the table above, and press the CASH TEND key.

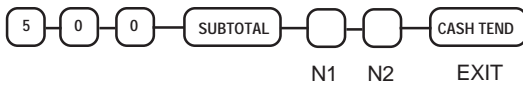

Second Programming Step

Assign up to a six digit HALO amounts for both check tender and over-tender (change) by entering 510 for tender, or 520 for over-tender, and pressing the SUBTOTAL key. Now enter up to a six digit (0-9999.99, 0 for no HALO) amount for the limit, and press the CASH TEND key.

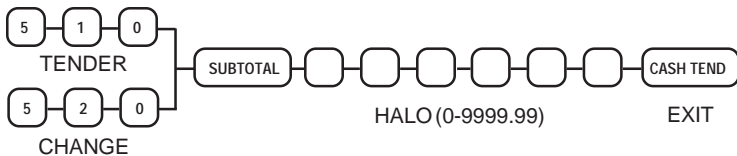

CHARGE Key 1 - 2 Programming

Programming Options

Carry the desired value for addresses with single options directly to the "SUM" column. For addresses with multiple choices, enter values of individual options in "=" column, add, and enter the combined value in the "SUM" column.

ADDRESS	CHARGE OPTIONS	VALUE	=	SUM	
N1	Sale is Exempt from Tax 1	YES = 1	(A)		
		NO = 0			
	Sale is Exempt from Tax 2	YES = 2	(B)		
		NO = 0			
	Sale is Exempt from Tax 3	YES = 4	(C)		(A+B+C)
		NO = 0			
N2	Non-add number entry is compulsory on charge tender.	YES = 1			
		NO = 0			

CHARGE Key Programming Key Sequence

First Programming Step

Enter the program address for a CHARGE key, 601 for charge 1, 602 for charge 2 and press SUBTOTAL. Enter the desired status, from the table above, and press the CASH TEND key.

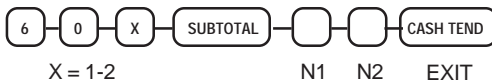

Second Programming Step

Key in the program address for programming the charge key tender limit, 611 for charge 1, 612 for charge 2 and pressing the SUBTOTAL key. Enter up to a six digit amount HALO (0-9999.99, 0 for no HALO) for maximum amount allowed on a charge sale and press the CASH TEND key.



Currency Conversion Programming

Setting the Exchange Rate

The Foreign exchange rate is determined based on a six digit code entered during this programming step. Digits N1 - N5 contain the numeric value of the exchange rate. N6 sets the decimal point position (0-5), counting from the right of the fifth digit.

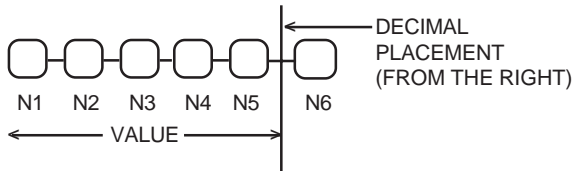

Programming Key Sequence

- A) Enter 801 for currency exchange key 1 programming.
Enter 802 for currency exchange key 2 programming.
- B) Enter the six digit rate code, press CASH TEND.

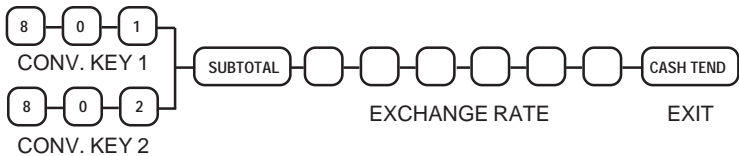

Programming Example

\$1.00 = \$1.33^{c/n} - In this example for the currency exchange key #1, the home currency is \$1.00/US, and the currency being exchanged is the Canadian dollar. The program code for this exchange rate would be 1 3 3 0 0 4, giving a numeric value of 13300 with the decimal at four places. The rate programmed is always the equivalent of one home currency unit.



Clerk Secret Code Programming

Before attempting this programming procedure, all clerks must first be signed off in REG. mode.

Also, in order to activate sign-on codes for clerks, system option programming for address #26 must be set to 2.

Programming Key Sequence

Enter the code for the CLERK key to be programmed. Enter 901 for clerk 1, 902 for clerk 2, 903 for clerk 3 and 904 for clerk 4, and press SUBTOTAL. Enter a clerk code number 1-6 digits long. Press CASH TEND key to finalize secret clerk key programming.



Clerk Drawer Assignment

Enter the code for the CLERK key to be programmed, 911 for clerk 1, 912 for clerk 2, 913 for clerk 3 and 914 for clerk 4, and press SUBTOTAL. Then enter 1 for drawer 1, or 2 for drawer 2, followed by the CASH TEND key to finalize drawer assignment.

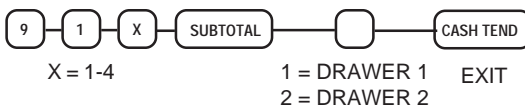

NOTE: Default drawer assignment for all clerks is drawer 1.

Programming Clerk Descriptors

After converting letters for clerk names into two-digit alpha-numeric codes, begin programming by entering the program address (1400) and pressing SUBTOTAL. Now enter the two-digit code for the clerk to be programmed and press PAID OUT. Now enter up to 24 digits for the descriptor and press the PAID OUT key again. Press the CASH TEND key to exit descriptor programming, or enter the code for the next clerk descriptor to be programmed.

Clerk Codes

CLERK 1=1, 2=2, 3=3, and 4=4.

Alpha Codes

DESCRIPTOR CODES										
CHAR	SPAC	!	"	#	\$	%	&	'	()
CODE	32	33	34	35	36	37	38	39	40	41
CHAR	*	+	,	-	.	/	0	1	2	3
CODE	42	43	44	45	46	47	48	49	50	51
CHAR	4	5	6	7	8	9	:	;	<	=
CODE	52	53	54	55	56	57	58	59	60	61
CHAR	>	?	@	A	B	C	D	E	F	G
CODE	62	63	64	65	66	67	68	69	70	71
CHAR	H	I	J	K	L	M	N	O	P	Q
CODE	72	73	74	75	76	77	78	79	80	81
CHAR	R	S	T	U	V	W	X	Y	Z	[
CODE	82	83	84	85	86	87	88	89	90	91
CHAR	\]	^	-	`	DOUBLE WIDE		Double wide characters must be preceded w/ "99", and count as two characters		
CODE	92	93	94	95	96	99				

Clerk Descriptor Programming Key Sequence

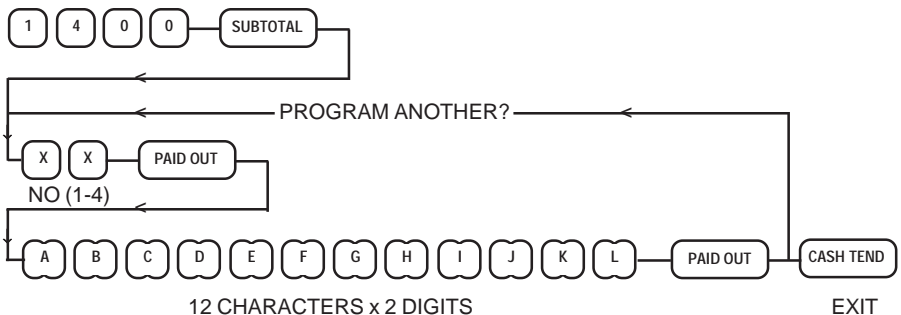

System Options Programming

Programming Options

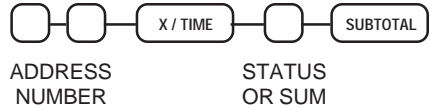

Carry the desired value for addresses with single options directly to the “SUM” column. For addresses with multiple choices, enter values of individual options in “=” column, add, and enter the combined value in the “SUM” column.

ADDRESS	SYSTEM OPTION	VALUE	=	SUM
1	Subtotal without tax will print on receipt and journal. Does not require depression of the SUBTOTAL key.	YES = 1	(A)	
		NO = 0		
	Allow % KEY preset override.	YES = 2	(B)	(A+B)
		NO = 0		
2	Tax amount charged will print on receipt at finalization.	YES = 0	(A)	
		NO = 1		
	Tax amount to print on receipt at finalization is: * Itemized tax print lists each rate separately, while combined tax print lists total of all taxes. Tax print (first option) must be set to "YES" in to allow these options.	Itemized = 0	(B)	
		Combined = 2		
	Print taxable totals.	YES = 4	(C)	(A+B+C)
NO = 0				
3	Inhibit Grand total print on financial report.	YES = 1	(A)	
		NO = 0		
	Print Grand total on X report. (Only if A = 0)	YES = 2	(B)	(A+B)
		NO = 0		
4	Skip Media totals with zero activity on financial report.	YES = 0	(A)	
		NO = 1		
	Print abbreviated Financial report (See Reports section).	YES = 2	(B)	
		NO = 0		
	Suppress print of Void/Return on financial report.	YES = 4	(C)	(A+B+C)
		NO = 0		
5	Inhibit Time print on receipt and journal.	YES = 1		
		NO = 0		
6	Inhibit Date print on receipt and journal.	YES = 1		
		NO = 0		
7	The date format will print as:	dd / mm / yy = 1	(A)	
		mm / dd / yy = 0		
	Check Validation Amount is:	Amount Tendered = 2	(B)	(A+B)
		Amount of Sale = 0		

ADDRESS	SYSTEM OPTION	VALUE	=	SUM
8	Inhibit printing of Positive department and PLU entries on journal. (Journal skip)	YES = 1	(A)	
		NO = 0		
	Print PLUs and Dept.s with zero totals on reports.	YES = 2	(B)	(A+B)
		NO = 0		
9	VAT (value added tax) will print on the receipt and journal separate from the cost of the taxable item. NOTE: An item taxable at 10% and registered at \$1.00 would print .09 as tax.	YES = 1		
		NO = 0		
10	Decimal for display:	no decimal = 1		
		set at two places = 0		
11	Print media totals on cashier reports. NOTE: Setting this option to "YES" will print totals for each of the media keys on cashier reports.	YES = 1		
		NO = 0		
12	Print sales % on Dept./PLU reports.	YES = 1		
		NO = 0		
13	Cash declaration is compulsory before taking X/Z reports.	YES = 1		
		NO = 0		
14	Voids are allowed in the 'X' control lock position only.	YES = 1	(A)	
		NO = 0		
	Voids require validation.	YES = 2	(B)	
		NO = 0		
	Allow multiple validations/ buffered receipt.	YES = 4	(C)	(A+B+C)
		NO = 0		
15	Cancel Function is allowed in the 'X' control lock position only.	YES = 1		
		NO = 0		
16	Merchandise Returns are allowed in the 'X' control lock position only.	YES = 1	(A)	
		NO = 0		
	Merchandise Returns require validation.	YES = 2	(B)	(A+B)
		NO = 0		
17	% key operations are allowed in the 'X' control lock position only.	YES = 1	(A)	
		NO = 0		
	Do % key operations require validation?	YES = 2	(B)	(A+B)
		NO = 0		
18	Received On Account, and Paid Out are allowed in 'X' control lock position only.	YES = 1	(A)	
		NO = 0		
	Do Received On Account, and Paid Out operations require validation?	YES = 2	(B)	(A+B)
		NO = 0		

System Options Programming, continued

ADDRESS	SYSTEM OPTION	VALUE	=	SUM
19	Consecutive number resets after Z1 financial report.	YES = 1	(A)	
		NO = 0		
	Do Check Key operations require Validation?	YES = 2	(B)	(A+B)
		NO = 0		
20	Grand total resets after Z1 financial report.	YES = 1	(A)	
		NO = 0		
	Do CHARGE 1 operations require Validation?	YES = 2	(B)	
		NO = 0		
	Do CHARGE 2 operations require Validation?	YES = 4	(C)	(A+B+C)
		NO = 0		
21	Negative sales total are allowed. NOTE: If set to "NO", an error will occur if a negative or zero balance sale is finalized. However, this compulsion can be overridden in X-Mode.	YES = 0		
		NO = 1		
22	Disable No Sale function.	YES = 1	(A)	
		NO = 0		
	Inhibit No Sales after non-add number entry.	YES = 2	(B)	(A+B)
		NO = 0		
23	Validation is compulsory with Add Check operation:	YES = 1	(A)	
		NO = 0		
	HASH Department & PLU operations add to NET sales:	YES = 2	(B)	(A+B)
		NO = 0		
24	Compulsory drawer is disabled.	YES = 1		
		NO = 0		
25	Enter number of digits for HALO Amount on Received On Account and Paid Out.	1-7		
26	Clerks are:	Pop-Up = 1	(A)	
		Stay Down = 0		
	Clerk Sign-On Method is:	Secret Sign On = 2	(B)	(A+B)
		Push Button = 0		
27	Inhibit Check cashing feature.	YES = 1	(A)	
		NO = 0		
	Check cashing allowed in X position only.	YES = 2	(B)	(A+B)
		NO = 0		
28	CURRENCY Logo is:	"." = 1		
		"\$" = 0		

ADDRESS	SYSTEM OPTION	VALUE	=	SUM
29	% calculations will: NOTE: % calculations include %+, %-, and % tax calculations.	round up at .50 = 0		
		always round up = 1		
		always round down = 2		
30	Rounding factor for split pricing and decimal multiplication.	round up at .50 = 0		
		always round up = 1		
		always round down = 2		
31	System uses:	Tax 3 / GST = 1		
		Food Stamps = 0		
32	Allow Post Tender Function.	YES = 1		
		NO = 0		
33	Enforce Non-add # key entry at beginning of sale.	YES = 1		
		NO = 0		
34	Number of digits required for Non-add # entry. (0 allows any length, 1-7 digits)	0 - 7		
35	Disable Department/PLU preset/HALO override.	YES = 1		
		NO = 0		
36	Activate Preset Tender Feature: FOOD STAMP becomes \$5.00 CHARGE 1 becomes \$10.00 CHARGE 2 becomes \$20.00	YES = 1		
		NO = 0		
37	Header message on receipt is:	Stamp Only = 0		
		Stamp & Prog. Logo = 1		
		Programmable Only = 2		
38	Activate Validation Sensor	YES = 1		
		NO = 0		
39	Allow Eight-digit DEPT. & PLU amount entries. NOTE: Maximum 8 digit amount is 500,000.00. 7 digit max is 99,999.99.	YES = 1		
		NO = 0		
40	Allow decimal entry of Food Stamp Tendered?	YES = 1		
		NO = 0		
41	Final Validation is:	Total of Sale = 1		
		Last Tender = 0		
42	Department Shift key is active (15 department configuration only.)	YES = 1		
		NO = 0		

System Options Programming Key Sequence

Enter the address number, depress the X/TIME key. Enter the status number, or the *sum* of the options, and depress the SUBTOTAL key.

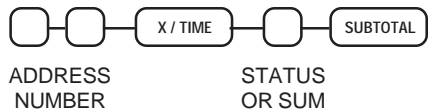

Receipt Message Programming

Three lines of twenty-one characters each may be programmed to print on all receipts and reports. This option is enabled by giving system option 37 a value of "1" or "2". (See page 29.)

After converting letters for each line to be programmed into two-digit alpha-numeric codes, begin programming by entering the program address (1500) and pressing SUBTOTAL. Now enter the single-digit code for the line to be programmed and press PAID OUT. Enter up to 42 digits (21 characters x 2 digits) for the descriptor and press the PAID OUT key again. Press the CASH TEND key to exit descriptor programming, or enter the code for the next line to be programmed.

Alpha Codes

DESCRIPTOR CODES										
CHAR	SPAC	!	"	#	\$	%	&	'	()
CODE	32	33	34	35	36	37	38	39	40	41
CHAR	*	+	,	-	.	/	0	1	2	3
CODE	42	43	44	45	46	47	48	49	50	51
CHAR	4	5	6	7	8	9	:	;	<	=
CODE	52	53	54	55	56	57	58	59	60	61
CHAR	>	?	@	A	B	C	D	E	F	G
CODE	62	63	64	65	66	67	68	69	70	71
CHAR	H	I	J	K	L	M	N	O	P	Q
CODE	72	73	74	75	76	77	78	79	80	81
CHAR	R	S	T	U	V	W	X	Y	Z	[
CODE	82	83	84	85	86	87	88	89	90	91
CHAR	\]	^	-	`	DOUBLE WIDE		Double wide characters must be preceded w/ '99', and count as two characters		
CODE	92	93	94	95	96	99				

Receipt Message Programming Key Sequence

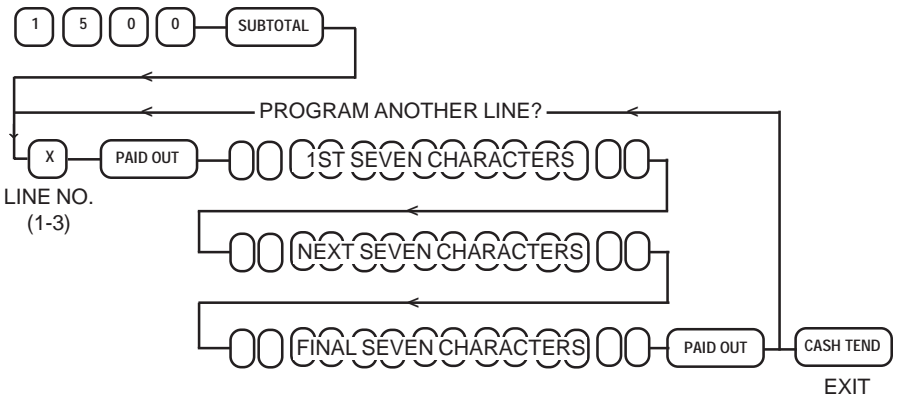

Drawer Limit Programming

Enter 1000 and press SUBTOTAL, and then enter the total amount of cash and checks allowed to be in the drawer at one time. Press the CASH TEND key to finalize programming.

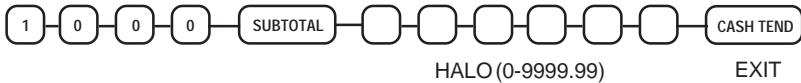

NOTE: If the drawer limit is exceeded, error tone will sound. The tone will sound each time a sale is finalized as long as the limit is exceeded. The clear key will stop the error tone.

Register Number Programming

Enter 1100 and press SUBTOTAL, and then enter up to a four-digit register number. Press the CASH TEND key to finalize programming.

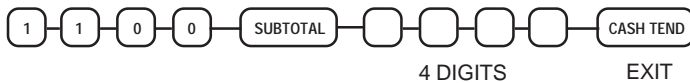

Date Programming

In P-mode, enter month, day, and year and day of the week (0 = Sunday, 1 = Monday, 2 = Tuesday, etc.); depress the X/TIME key.

For example, Saturday June 12, 1993 would be entered as:

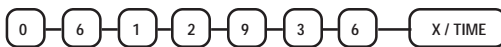

Time Programming

Enter time in military standard time (based on 24 hours), must be four digits (i.e. 1300 hours = 1:00 PM), depress the X/TIME key.

2:00 PM would be entered as:



Program Scans

Since much time and energy has been invested in the planning and programming of your SAMSUNG ER-4915, it is advisable to print a hard copy of the final program for future reference. This copy should be kept in a safe place.

Keylock in Programming position:

Tax Program Scan

Depress the CASH TEND key, then the TAX 1 SHIFT key for Tax 1 read-out; or depress the CASH TEND key, then the TAX 2 SHIFT key for Tax 2 read-out.

The read-out will be the same as receipt during programming.

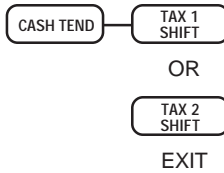

Department Program Scan

Depress the CASH TEND key, then the first department key to be read, and the last department key to be read.

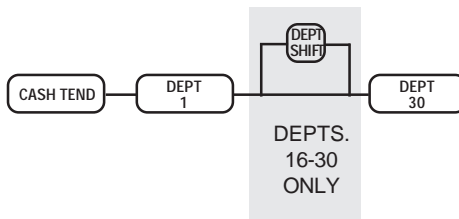

NOTE: DEPT SHIFT functions as “Stay Down” in P-mode only.

PLU Program Scan

Depress the CASH TEND key; then enter the number of the first PLU to be read, depress the PLU key; then enter the number of the last PLU to be read, depress the PLU key.

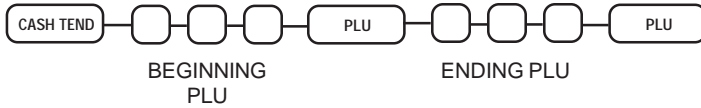

Options Program Scan

Depress the CASH TEND key, then the SUBTOTAL key.

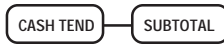

Programmable Message Program Scan

Depress the CASH TEND key, then the PAID OUT key.



System Reports

REPORT TYPE	REPORT NUMBER	REPORT MODE	KEYLOCK POSITION	KEY SEQUENCE
Financial	1	X	X	1 SUBTOTAL
		Z	Z	1 SUBTOTAL
		X2	X	201 SUBTOTAL
		Z2	Z	201 SUBTOTAL
Time	2	X	X	2 SUBTOTAL
		Z	Z	2 SUBTOTAL
		X2	X	202 SUBTOTAL
		Z2	Z	202 SUBTOTAL
PLU	3	X	X	3 SUBTOTAL
		Z	Z	3 SUBTOTAL
		X2	X	203 SUBTOTAL
		Z2	Z	203 SUBTOTAL
Cash-In-Drawer	4	X	X	4 SUBTOTAL
Check-In-Drawer	5	X	X	5 SUBTOTAL
Foodstamp-in-Drawer	6	X	X	6 SUBTOTAL
Daily Sales	7	X	X	7 SUBTOTAL
		Z	Z	7 SUBTOTAL
Individual Clerk Report		X	X	SUBTOTAL, CLERK KEY
		Z	Z	SUBTOTAL, CLERK KEY
		X2	X	20 SUBTOTAL, CLERK KEY
		Z2	Z	20 SUBTOTAL, CLERK KEY
From/To Department		X	X	Beginning Department Key, Ending Department Key
From/To PLU		X	X	Beginning PLU Number, PLU Key Ending PLU Number, PLU Key

System Balancing

1. Department Sales Total

The sum of all department totals:

Add all positive departments, subtract all negative departments.

2. Net Sales

+/-	NET SALES	\$
=	Department Sales Total	\$
+	Tax 1	\$
+	Tax 2	\$
+	Tax 3	\$
+	Sale Coupon Total	\$
+	Sale Percent Discount	\$
+	Surcharge Sale	\$
=	Net Sales	\$

3. Gross Sales

+/-	GROSS SALES	\$
=	Net Sales	\$
-	Negative Departments*	\$
-	Item Coupon	\$
-	Item Percent Discount	\$
-	Sale Coupon	\$
-	Sale Percent Discount	\$
-	Credit Tax 1	\$
-	Credit Tax 2	\$
-	Credit Tax 3	\$
-	Merchandise Return	\$
-	Void Position Total	\$
-	(-) PLU linked to (+) Depts.*	\$
=	Gross Sales	\$

4. Ending Grand Total = Previous Grand Total
 + Absolute Value of Today's Gross Sales Total



(Office Products Division)
2909 Anthony Lane N.E.
Minneapolis, Minnesota 55418
612/781-3474

© 1993, Cash Register Sales, Inc.

All specifications are subject to change without notice.

OP83